

Since the usage and finishing of the product is not under our control, we accept no liability for the success of our products as per the accompanying product data sheets and in accordance with our general terms and conditions of sale. The properties listed here represent no guarantee with respect to the eventual use of our products. We reserve the right to make changes due to technical advances. Any other technical information given in the course of a consultation must be confirmed in writing. Colours shown here are restricted by the printing techniques and may differ from those exhibited by the products themselves. We also reserve the right to make alterations to the product technology or design. Only the current version of this data sheet is valid. Such versions are accessible by anyone via the internet. The issue of the latest data sheet invalidates all those that have been published beforehand.

DURAFLEX

1/2

Expansion joint profiles for subsequent installation – SF series

- Information Sheet -

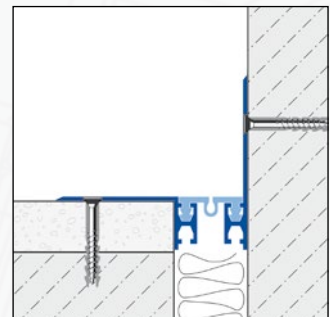
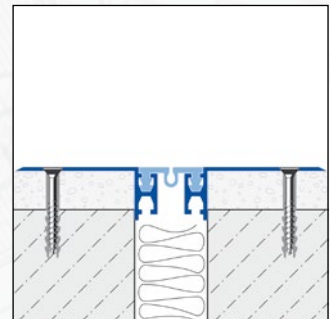
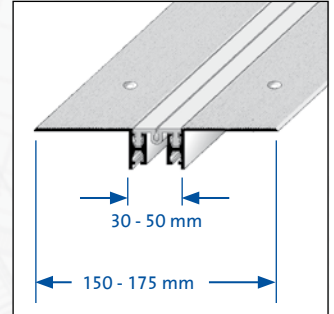

APPLICATION:

Expansion joint profiles for subsequent installation indoors and outdoors with a nitrile rubber inlay, available in two widths and corner versions. Suitable for all weight-bearing and straight sub-surfaces.

This elastic expansion joint profile was specially developed for subsequent installation in highly-frequented areas such as shopping centres, warehouses and production facilities. Bonded and screwed to the floor with extra-wide contact surfaces, it durably and stably withstands large loads. The elastic joint inlay in nitrile rubber absorbs horizontal and vertical expansion and deforming stresses and reduces the conduction of footfall sound.

The following information is applicable to all products/materials: the suitability of the profile with respect to mechanical and chemical loads must be checked carefully in each individual installation case. The generally accepted regulations of technology and good engineering practice must always be observed.

Joint inlay:	Nitrile rubber (interchangeable)
Movement absorption:	12 mm (+ 8 / - 4 mm)
For joint widths up to:	50 mm
Load:	Forklift = 25 KN
Profile fixing:	Professional anchoring on the load-bearing sub-surface according to the degree of loading at intervals of approximately 30 - 50 cm
Deformation absorption from the sub-surface:	horizontal and vertical

DURAL GmbH
 Südring 11
 D-56412 Ruppach-Goldhausen
 Tel. +49 (0) 2602/9261-0
 Fax +49 (0) 2602/9261-50
 info@dural.com

Expansion joint profiles for subsequent installation – SF series

- Information Sheet -

PROCESSING:

Depending on the application area, press the joint profile with the self-adhesive effect firmly onto the cleaned and dry sub-surface. For medium loading, screw the profile onto the sub-surface using correspondingly large dowels at intervals of approx. 30 cm.

CARE:

DURAFLEX expansion joint profiles do not require any special care and are resistant to mould and bacteria. Detergents must be non-abrasive and free from hydrochloric or hydrofluoric acids. Use neutral detergents only.

PRODUCT DATA:

MATERIAL:	Aluminium natural
INLAY / COLOUR:	Nitrile rubber / grey
VISIBLE WIDTH:	150 / 175 mm (corner version: 90 / 115 mm)
JOINT WIDTH:	30 / 50 mm
PROFILE LENGTH:	400 cm

DURAL GmbH

Südring 11

D-56412 Ruppach-Goldhausen

Tel. +49 (0) 2602/9261-0

Fax +49 (0) 2602/9261-50

info@dural.com